

FFT Secure Link™ Installation Overview

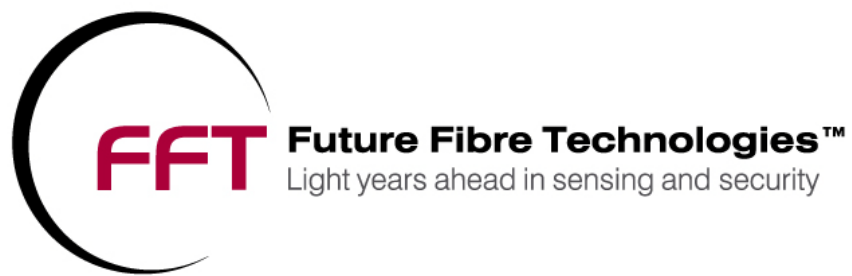

The information in this document is subject to change without notice. No part of this document may be reproduced or transmitted in any form or by any means, electronic or mechanical, for any purpose, without the express written permission of Future Fibre Technologies Pty. Ltd. Future Fibre Technologies Pty. Ltd. may have patents or pending patent applications, trademarks, copyrights, or other intellectual property rights covering subject matter in this document. The furnishing of this document does not transfer rights or license to these patents, trademarks, copyrights, or other intellectual property except as expressly provided in any written license agreement from Future Fibre Technologies Pty. Ltd.

© 2002-2009 Future Fibre Technologies Pty. Ltd. All rights reserved.
Printed in Australia.

Document Title: *FFT Secure Link™ Installation Overview*
Document Number: 9990 3008 021, Version 2.1

Future Fibre Technologies Pty. Ltd., the Future Fibre Technologies logo, FFT Secure Fence, FFT Secure Link, FFT Secure Pipe, FFT Secure Zone, FOSS, FOSL, FOSF, FOPSS, FFT CAMS, FFT TAZ, FFT Locator, FFT Microstrain/Locator, ARaD and Foptic are either registered trademarks or trademarks of Future Fibre Technologies Pty Ltd. Incorporated in Australia, the USA and/or other countries.

Microsoft, MS, MS-DOS, and Windows are registered trademarks of Microsoft Corporation.

How It Works

Secure Link™ Microstrain was designed to overcome the risk of illegal ‘eavesdropping’ or Third Party Interference by providing the ultimate level of protection against any attempt to physically tamper with or interfere with IT or communications cables. Using Singlemode fibre optic cable as its sensor, movement, vibration and sound acting on the cable, or the cable bundle it is attached to, is detected.

Referring to Fig 1 the Secure Link Microstrain Locator sensor is based on interferometry where two of the fibers within the sensing cable form the arms of an interferometer. Using a coherent laser, CW light is propagated through the arms of the sensor. When there is an external interference on the sensing fibers (motion, sound or vibrations) an interference pattern will be generated. The Sensing Controller will detect this change and the FOSS software will interpret the effect as either an intrusion event, or reject it as ambient conditions.

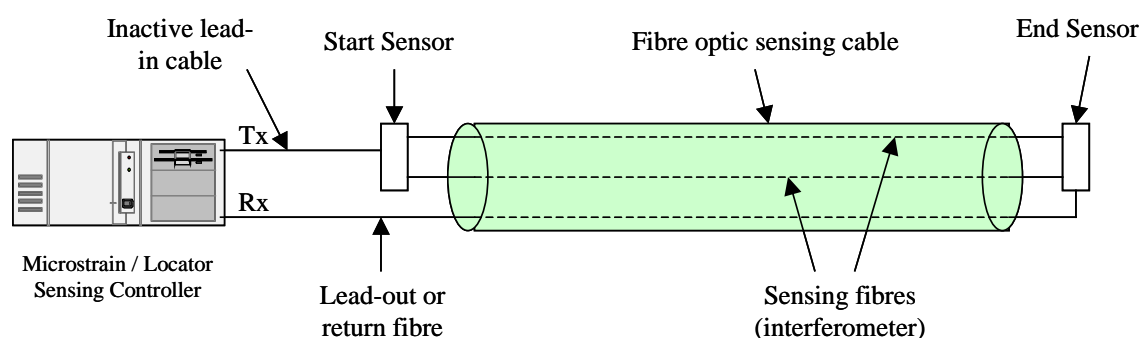

Fig 1: Secure Link System

The Sensing Controller identifies the event and can, through the FOSS software, determine the type of event. Using the unique recognition features in FOSS, we can limit nuisance alarms created by ambient noise and nuisance events to minimal levels while ensuring >95% detection of intrusion events.

FFT Secure Link™ provides an unlimited amount of zones using 3 optical fibres within the one cable, and is able to detect and locate multiple tampering or intrusions events in real time.

The Locator portion of the system can locate any intrusion attempt to within 25 meters. This unique feature allows you to pinpoint the intrusion location on network lengths of hundreds of kilometres. It also reduces the number of systems required, since multiple fixed zones and the associated hardware are not required. It should be noted that the return or Lead-out fibre can follow a completely different path in a different cable – it does not need to follow the same path as the interferometer at all.

Power is not required along the network for FFT Secure Link™ (other than at the monitoring posts), nor is the sensing cable at risk of damage from electrical interference, lightning strikes, EMI, or RFI.

Secure Link™ is effectively a fibre optic ‘microphone’, combining the characteristics of a piezo-electric transducer and strain gauge sensor, designed to detect disturbances generated by TPI activities and tampering of the protected network, while discriminating between normal ambient conditions. The Secure Link system is very sensitive to minute cable movements and the frequencies of the sound or pressure waves generated by TPI. Through the use of intelligent signal processing, these can be isolated from other environmental signals for clear identification, with minimal false alarm and nuisance alarm rates.

Secure Link is already installed in numerous commercial, military and government applications. As you can see in Fig 3, the system comprises an optical fibre cable laid in close proximity or strapped to the cable bundle and a Secure Link Sensing Controller, containing the opto-electronics, data acquisition hardware and signal processing software, installed at one end of the network (section) to be monitored. FFT can also supply FFT CAMS (Central Alarm Monitoring System) and integrate a number of these Secure Link systems into the one central monitoring unit.

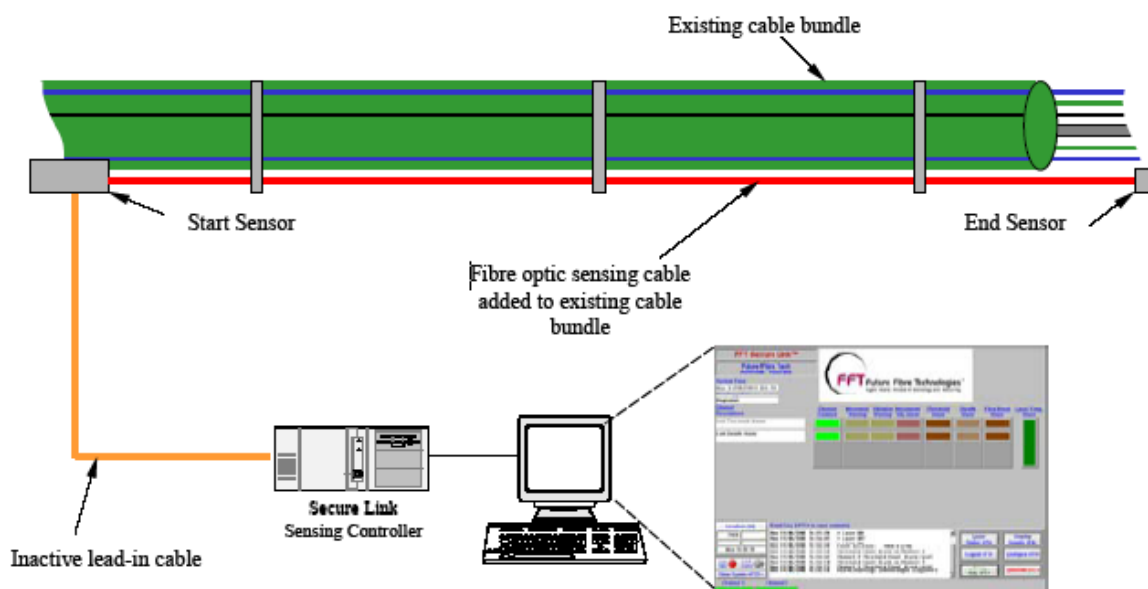

Fig 2: Basic FFT Secure Link™ layout.

More commonly, if the network cable has three single mode fibres that are not in use, Secure Link™ can actually utilise these unused fibres rather than lay an additional sensing cable to significantly reduce installation times and costs. The sensitivity of FFT’s Secure Link™ System on the other hand, is not significantly affected.

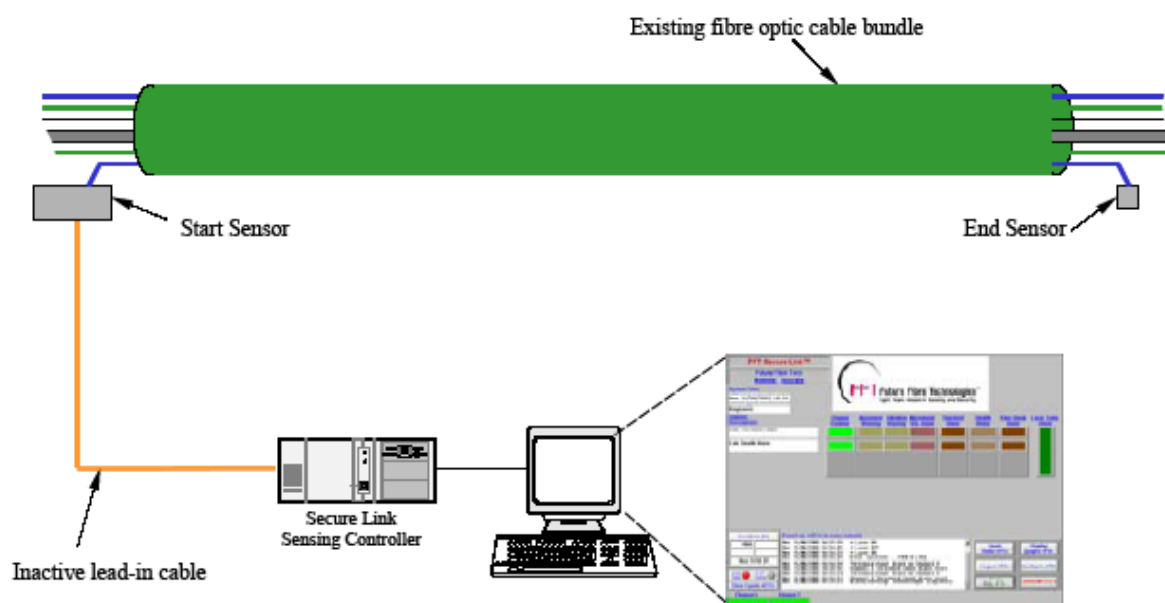

Fig 3: FFT Secure Link™ Buried Sensing Cables.

FFT Secure Link™ is ideally suited to longer distance networks because of the nature of optical sensors. The response of an optical fibre to physical interference is consistent regardless of the distance at which the incident occurs.

A most important aspect of FFT Secure Link™ is that no external electronics, optics or control hardware is required.

Sensing Distances

A major advantage of using FFT Secure Link™ is the consistency of the detection response over ring network of up to 80 kilometers or 50 miles (total optical path length) without the need for any external hardware other than the fiber optic cable itself. In a straight line, this distance is 40km (40km out plus 40km return path = 80km light path) – refer to Fig 4 on page 8.

The actual distance achievable is limited by optical an power budget of 25dB, which translates into an optical path length of 80km depending on the quality of the fiber optic cable and the number and quality of the splices and general installation. The optical path length compromises the "lead-in", sensing cable length, return path (if not a loop or ring configuration) and "lead-out" cable. Multiple systems can be cascaded together to protect longer networks.

Zoning

Via CAMS, the Secure Link system has the flexibility to be configured either as a large single zone sensor or as multiple smaller zones. These zone lengths are software configurable, so you can break down the one sensor cable into multiple zones of varying lengths to correspond with the positions of CCTV's, cross streets, access pits etc. A matrix switcher interface is optionally available within CAMS to interface and control Pelco P series switchers using ASCII Protocol.

If these zones are kept short and manageable, then it is much simpler to locate with greater accuracy where an intrusion has occurred.

Third Party Interference (TPI)

In many situations secure network owners and operators recognise the expense and inconvenience of accidental or deliberate attempts to physically interfere or tamper with a secure network. Secure Link™ provides the possibility of warning about such incidents prior to serious damage occurring.

In other cases, deliberate attempts are made to illegally tap into the contents of networks. The Secure Link™ Third Party Interference capability is designed to minimise the possibility of these incidents.

Interference Immunity

One specific benefit of fiber optic based systems is their immunity to electromagnetic interference, particularly important for installations near high voltage electrical equipment, or in areas subject to lightning strikes, electromagnetic pulses, strong magnetic fields, or RFI.

Intrinsically safe

Another important aspect of FFT Secure Link™ is that no power, external electronics, or control hardware is required in the field other than for the sensing controller located at the start of the network. There is no power applied to or near the network itself, and the start and end sensors are passive optical devices also requiring no power.

Detectability

Due to the nature of fiber optic cables, it is impossible to detect the presence of Secure Link within a cable bundle, providing a totally covert interference and intrusion detection system.

Interfacing

FFT Secure Link™ systems also have the flexibility to interface to a wide variety of local or remote security management systems so that it can integrate with supporting security technologies such as display systems, cameras, lights and audible alarms.

Fiber Optic Cable Installation

Planning

Detailed site and installation planning is essential for a smooth and successful installation, and the following points are critical to ensure a complete understanding of the capabilities of the system and avoid costly pitfalls.

A proper network layout is required to determine where best to place the controller(s) and the fiber optic sensing and lead in cables, plus determine the most efficient sensing fiber path whilst avoiding the sensing fibres actually doubling back on itself within the one cable.

Optical power budgets also need to be addressed on long or multi-zoned sites, and OTDR fiber testing at the completion of each stage of the installation must be carried out.

Distance that can be protected with a single Secure Link system

The FFT Secure Link™ sensing controller is typically capable of driving a total optical path length of up to 80km or 50 miles. The actual distance is limited by optical an power budget of 25dB @1550nm, which translates into an optical path length of 80 km or 50 miles depending on the quality of the fiber optic cable, the number and quality of the splices, number of connectors and general installation.

The optical path length comprises the "lead-in", sensing cable length, return path (if not a loop or ring network configuration) and "lead-out" cable. Referring to Fig 4, this total light path is the distance from the sensing controller to the end sensor and **back to** the sensing controller via the Lead-out fiber.

This means that if you are going out from the sensing controller in a straight line (single ended), the distance to the end sensor is a maximum of 40km (as you have to add the 40km for the return optical path).

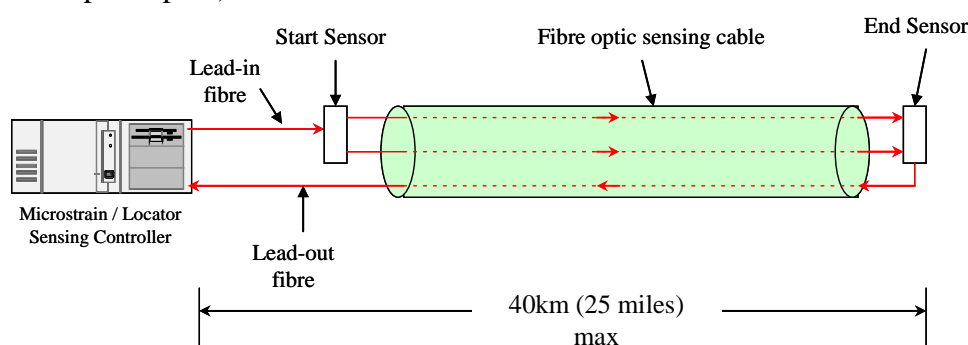

Fig 4: Single Ended configuration showing light path

If you are using a ring configuration where the start and end sensors are in the same location, then the total optical path length of 80km equates to a “network ring” length of 80km as the return path on the Lead-out fiber is very short.

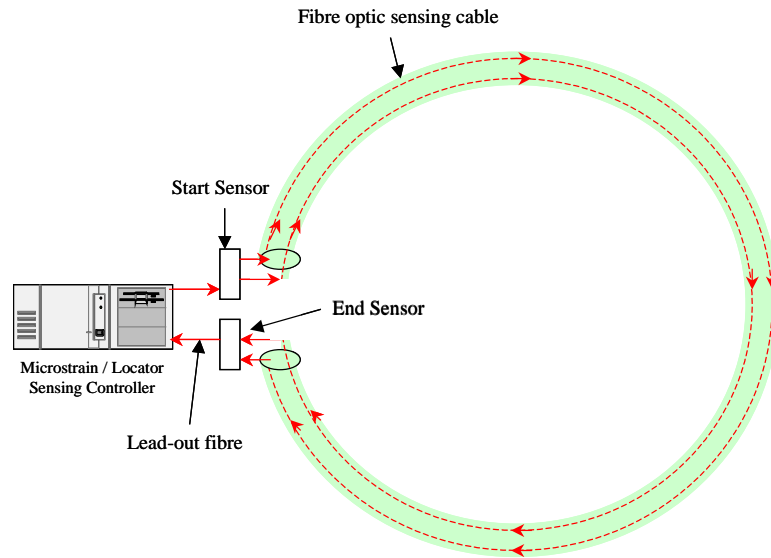

Fig 5: Ring configuration showing light path

Covering Longer Distances

Multiple FFT Secure Link™ systems can be easily installed for networks longer than 40km. The outputs from each of these sensing controllers can feed back into one centralized alarm monitoring system such as FFT’s CAMS. A typical long distance multi-system configuration would look as follows:

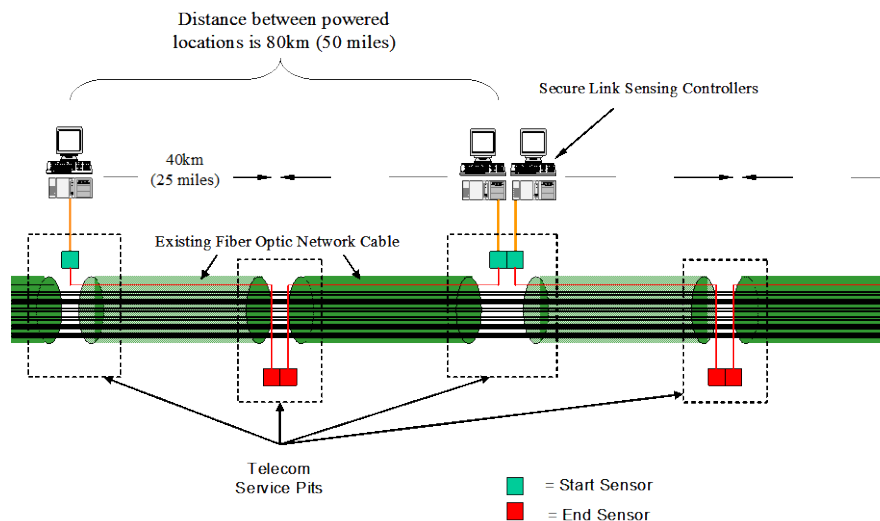

Fig 6: Multi-system configuration

Installing a New Sensing Cable

In its simplest form, to establish an alarmed network where there are no unused singlemode fibres available, a single continuous FFT Secure Link™ optical fiber sensing cable is run alongside the existing cable bundle and attached every 300mm with cable ties.

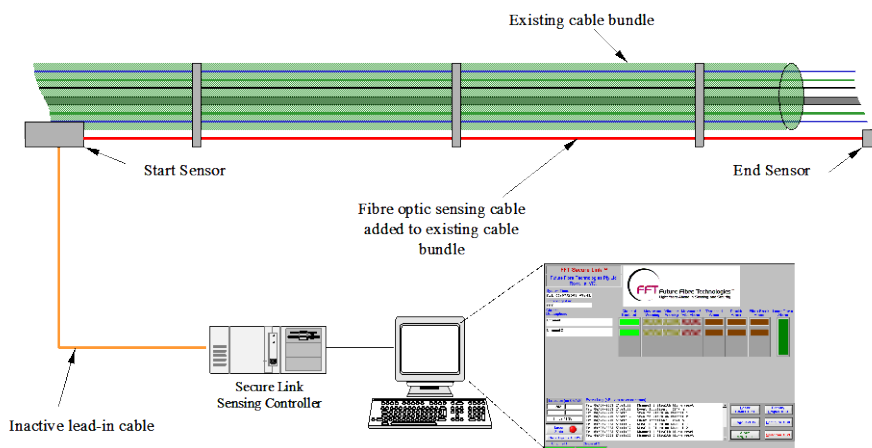

Fig 7: Basic Secure Link Configuration

Utilizing the Existing Cable as the Sensor

In the majority of installations and the preferred method, 3 unused singlemode fibres within the existing network cables are used as the Secure Link sensor. This existing cable may be spliced up as a single-ended sensor, or in a ring configuration.

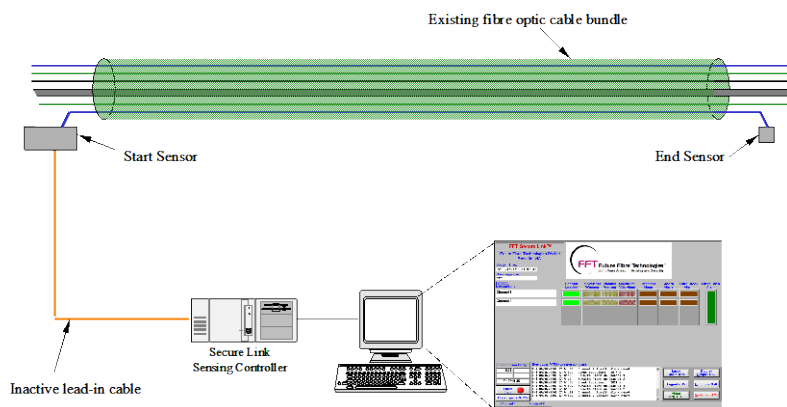
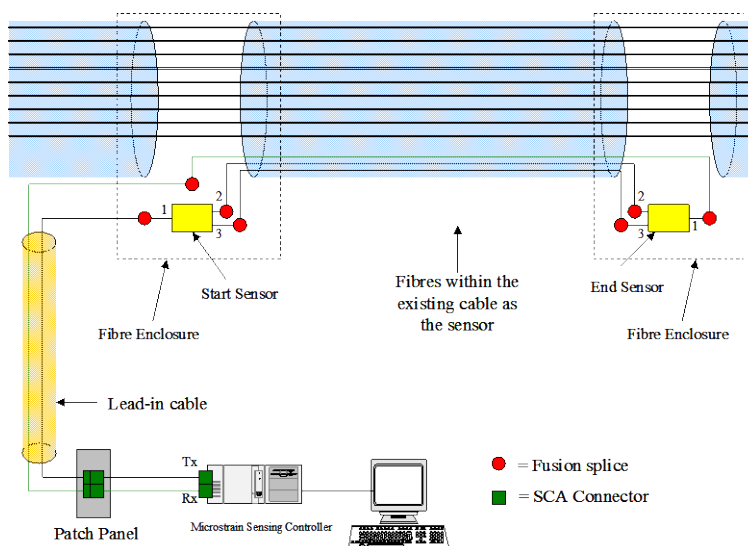

Fig 8: Secure Link Installation using existing fibre optic cable

In both of these installation examples (a separate sensor cable or utilizing unused fibres in an existing cable), a non-sensitive feeder cable is installed between the Sensing Controller and the sensing cable on the network.



The Start and End Sensors are spliced up to an existing communications cable as indicated below. Sometimes they are fitted to the patch panels at each end rather than breaking out the cable. The actual method used depends on the individual installation.

For more information on FFT Secure Link installation procedures, please contact your nearest Future Fibre Technologies office.

Contact Details:

Americas

Future Fibre Technologies (US) Inc.
800 West El Camino Real, Suite 180
Mountain View, CA 94040 USA

Toll Free: +1-877-650-8900
Outside the USA: +1 650 903 2222
Fax: +1 (435) 417-6671

Email: info@fft-usa.com

Asia Pacific

Future Fibre Technologies Pty. Ltd.,
10 Hartnett Close,
Mulgrave, Vic., 3170
Australia

Phone: +61 3 9590 3100
Fax: +61 3 9560 8000

Email: info@fft.com.au

Europe

Future Fibre Technologies Pty Ltd
3000 Hillswood Drive,
Hillswood Business Park
Chertsey, Surrey KT16 0RS
England

Phone: +44 (0)1932 895 317
Fax: +44 (0)1932 895 318

Email: info@fft-emea.com

Middle East

Future Fibre Technologies MENA FZ-
LLC
Building 11, Office G08
Dubai Internet City
United Arab Emirates

Phone: +971 4 434 5361
Fax: +971 4 439 3406

Email: info@fft-mena.com

Web: www.fftsecurity.com